



SINGLE-PHASE BRIDGE RECTIFIER

RB151 THRU RB157

**VOLTAGE RANGE
CURRENT**

**50 to 1000 Volts
1.5 Ampere**

FEATURES

- Low cost
- This series is UL recognized under component index, file number E127707
- High forward surge current capability
- Ideal for printed circuit board
- High temperature soldering guaranteed:
260°C/10 second, 0.375" (9.5mm) lead length at 5 lbs. (2.3kg) tension.

MECHANICAL DATA

- Case: Molded Plastic body
- Terminal: Lead solderable per MIL - STD - 202E method 208C
- Polarity: Polarity symbols marked on case
- Mounting position : Any
- Weight: 0.04 ounce, 1.15 gram

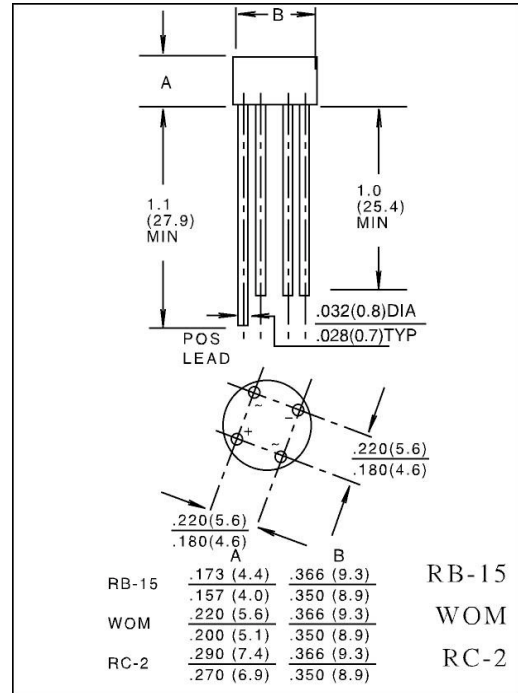

MAXIMUM RATINGS AND ELECTRICAL CHARACTERISTICS

- Ratings at 25°C ambient temperature unless otherwise specified
- Single phase, half wave, 60Hz, resistive or inductive load.
- For capacitive load derate current by 20%

	SYMBOLS	RB151	RB152	RB153	RB154	RB155	RB156	RB157	UNIT
Maximum Repetitive Peak Reverse Voltage	V_{RRM}	50	100	200	400	600	800	1000	Volts
Maximum RMS Voltage	V_{RMS}	35	70	140	280	420	560	700	Volts
Maximum DC Blocking Voltage	V_{DC}	50	100	200	400	600	800	1000	Volts
Maximum Average Forward Rectified Output Current, at $T_A = 25^\circ C$ (Note 2)	$I_{(AV)}$	1.5							Amps
Peak Forward Surge Current 8.3ms single half sine - wave superimposed on rated load (JEDEC method)	I_{FSM}	50							Amps
Rating for Fusing ($t < 8.3ms$)	I^2t	10							A^2s
Maximum Instantaneous Forward Voltage Drop per bridge element at 1.0A	V_F	1.0							Volts
Maximum DC Reverse Current at rate DC blocking voltage per element	$T_A = 25^\circ C$	10							μA
	$T_A = 100^\circ C$	0.5							mA
Typical Junction Capacitance (Note 1)	C_j	15							pF
Typical Thermal Resistance (Note 2)	$R_{\theta JA}$	40							$^\circ C/W$
Operating Temperature Range	T_J	(-55 to +125)							$^\circ C$
Storage Temperature Range	T_{STG}	(-55 to +150)							

NOTES:

1. Measured at 1.0 MHz and applied reverse voltage of 4.0 Volts.
2. Unit mounted on P.C. board with 0.22" X 0.22" (5.5 X 5.5 mm) copper pads.. 375" (9.5mm) lead length.

RATINGS AND CHARACTERISTIC CURVES RB151 THRU RB157

FIG.1-DERATING CURVE FOR
OUTPUT RECTIFIED CURRENT

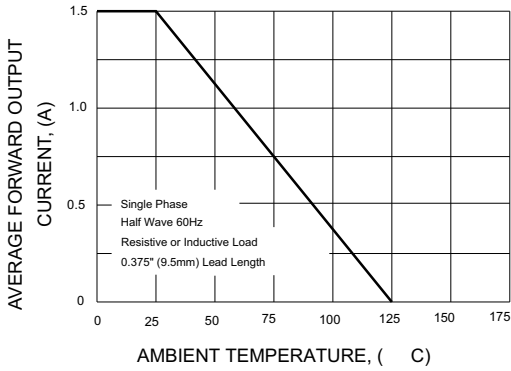

FIG.2-MAXIMUM NON-REPETITIVE PEAK
FORWARD SURGE CURRENT PER ELEMENT

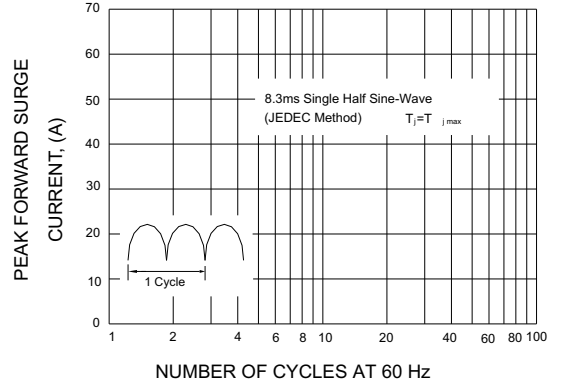

FIG.3-TYPICAL FORWARD CHARACTERISTICS
PER BRIDGE ELEMENT

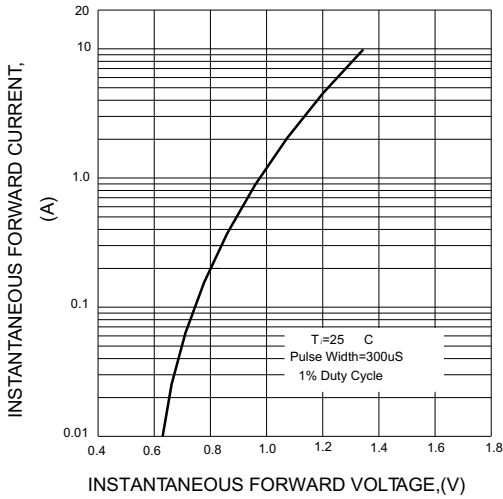

FIG.4-TYPICAL REVERSE CHARACTERISTICS
PER BRIDGE ELEMENT

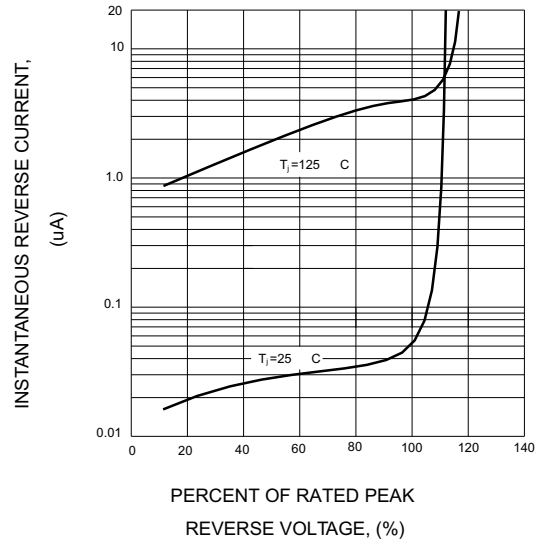

FIG.5-TYPICAL JUNCTION CAPACITANCE
PER BRIDGE ELEMENT

